

Fontana Chrome Automatic Sensor Deck Mounted Commercial Liquid Foam Soap Dispenser

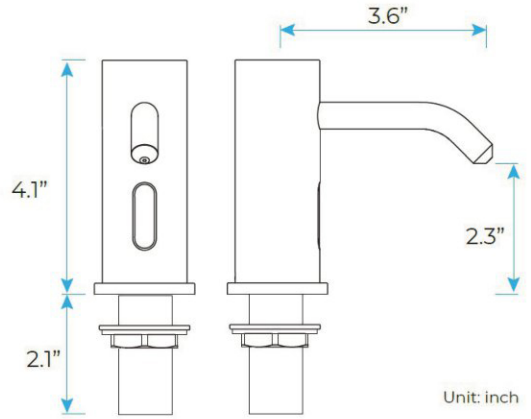

SPECS :

Product Type: Commercial

Main Construction Material: Brass

Mount Type: Deck

Handle Type: Infra-Red

Power Rating: 3 Amp Fuse, AC: 230V DC: 1.5V

Batteries Required: 4 AA Batteries (not supplied)

Number of Tap Holes: 1

Valve/Cartridge Type: Solenoid Valve

Plumbing System Requirements:

Suitable for all plumbing systems

Sensing Range: 0 - 8cm

Activation Time: 0.5 - 1 secs

Viscosity of Liquid Soap: 100-3500cp (mpA .s)

Isolation Included: No

