

# CHROME COMMERCIAL WATERFALL AUTOMATIC MOTION SENSOR FAUCET SPECIFICATIONS

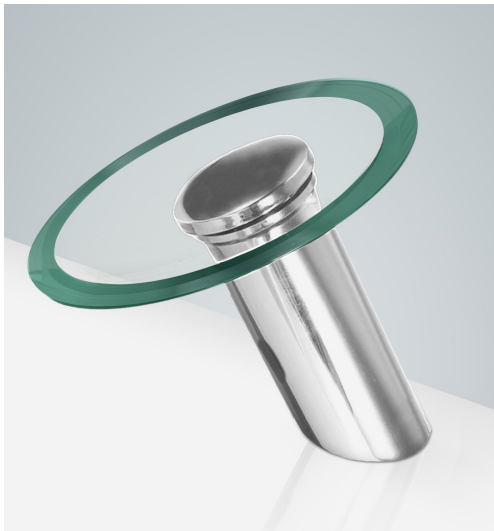

Size

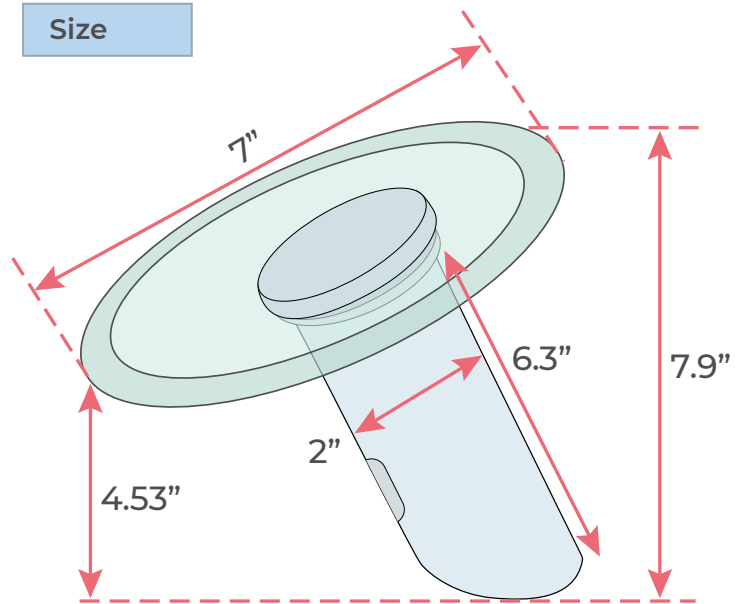

unit: inch

Specs

- Power: AC & DC 6V (batteries not included)
- Water Consumption: 0.05Mpa-0.6Mpa
- Detection Zone: 16-32 cm or adjustable
- Motor valve lifespan: up to 500000 flushes
- Battery lifespan: 100000 cycles
- Static Power Consumption: 0.36mw
- Working Power consumption: 0.5mw
- Inductive Opening Time: < 1 second
- Inductive Closing Time: < 2 second
- Dia.of inlet / outlet pipe: G1/2"
- Flux: ≥0.07L/S
- Power Supply: Box Transformer (BOX)
- Temperature Mixer: Below Deck Manual Mixing Valve (BDM)
- Factory Default Timeout: 30s
- Factory Default GPC: 0.75
- Working pressure: 0.05 - 1.6 Mpa
- Water flow: 1.2GPM (4.54 L/Min) @ 60PSI

Overview

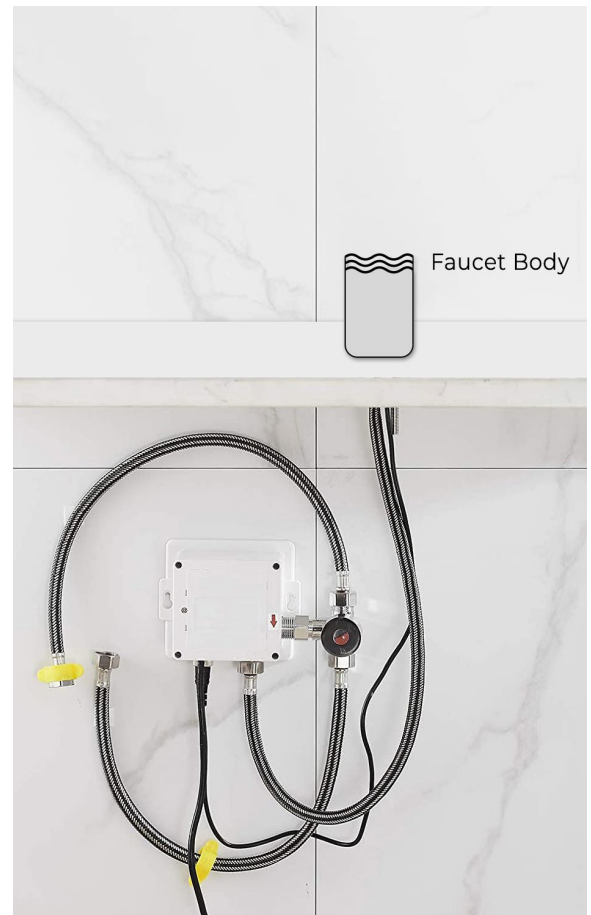

FEATURES

- Commercial Grade Faucet, ADA Compliant, Cast Brass Spout, Quick Connect Fittings, Integrated Water Shut-off, Hygienic Line Flush, Water Usage and Battery Strength Reporting, Self-adapting Sensor

All dimensions and specifications are nominal and may vary. Use actual products for accuracy in critical situations.