

## FONTANA HUGO COMMERCIAL OIL RUBBED BRONZE AUTOMATIC HANDS FREE FAUCET SPECS

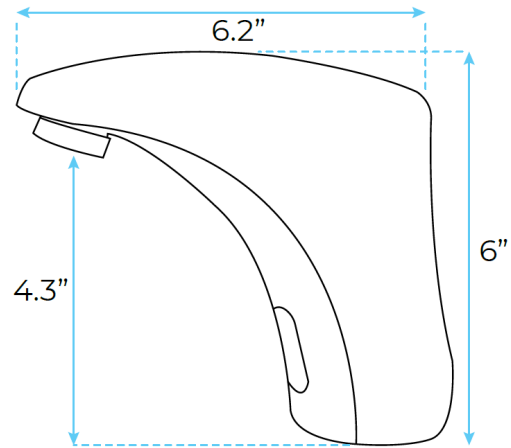

### **SPECS :**

Power: DC:6V(4AA alkaline battery)

AC:220V-240V; 50/60HZ

Water Consumption: 0.05Mpa-0.6Mpa

Detection Zone: 16-32 cm or adjustable

Motor valve lifespan: up to 500000  
flushes

Battery lifespan: 100000 cycles

Static Power Consumption: 0.36mw

Working Power consumption: 0.5mw

Inductive Opening Time: < 1 second

Inductive Closing Time: < 2 second

Dia.of inlet / outlet pipe: G1/2"

Flux:  $\geq 0.07L/S$

Temperature: 0.1-50°C

Water Pressure: 0.1 - 7.0 KGS/cm , 10 -  
125 psi

flow rate : 2.5 GPM

