

MELUN TOUCHLESS COMMERCIAL SOAP DISPENSER IN LIGHT OIL RUBBED BRONZE SPECIFICATIONS

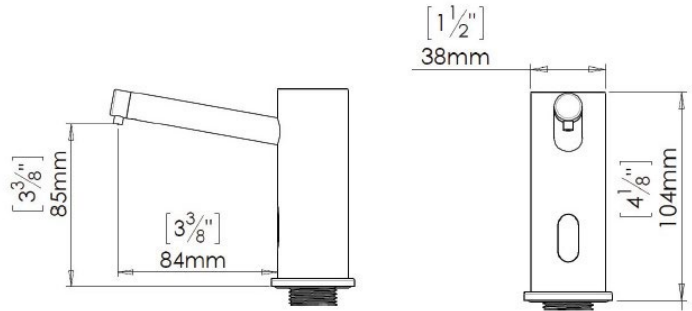

Size:



Specifications

- INSTALLATION: LAVATORY MOUNTED
- POWER SOURCE: 12 V TRANSFORMER
- DEFAULT SOAP DOSAGE: 1.4 CC
- SOAP VISCOSITY: 100-3800 CPS
- USAGE: COMMERCIAL: RESIDENTIAL
- INLET/OUTLET DIAMETER: G-1/2"
- ACTIVATION: INFRARED SENSOR
- SENSOR RANGE: SELF-ADJUSTING
- ACTIVATION TIME: < 1 SECOND

